

X540AJ

COMPACT CRAWLER

BOOM LIFT



AERIAL TITANS



KEY SPECS

Platform Height

54-ft / 16.46-m

Platform Capacity

500-lb / 227-kg

Horizontal Outreach

24-ft / 7.32-m

Overall Width

31-in / 0.78-m

KEY FEATURES

- Features a 500-lb unrestricted platform capacity with SkyGuard SkyLine™ standard.
- Environmentally friendly with standard AC powered boom functions with diesel, optional bi-energy or optional lithium-ion electrical system for emission-free operation.
- Access tight spaces and climb slopes with ease thanks to a narrow chassis and tracked wheel carriage.
- Transport with ease by a forklift or crane with forklift pockets and lifting points, and fits through standard doorway.

ACCESSORIES & OPTIONS

- Black Deep-Tread Tracks
- Bi-Energy Power Option - Includes Diesel Engine and Lithium-Ion Battery
- Radio Remote Control

STANDARD SPECIFICATIONS

Performance

Platform Height	54-ft / 16.46-m
Horizontal Outreach	24-ft / 7.32-m
Platform Capacity	500-lb / 227-kg
Swing	360 Degrees Non-continuous
Platform Rotation	124 Degrees (+62, -62 Degrees)
Jib (Range of Articulation)	89 Degrees (0, -89 Degrees)
Ground Bearing Pressure (Tracks)	8.8 psi / .62 kg/cm ²
Ground Bearing Pressure (Outriggers)	36 psi / 2.53 kg/cm ²
Drive Speed	1.6 mph / 2.5 km/h
Max Approach / Depart Angles	18° / 19°
Max Stabilization Slope	12 Degrees
Gradeability	28%
Weight* (Diesel)	6,239-lbs / 2,830-kg
Weight* (Lithium)	6,349-lbs / 2,880-kg
Weight* (Bi-Energy)	6,592-lbs / 2,990-kg

*Certain options or country standards increase weight

Power

Engine: Kubota Diesel	14.5 hp
Fuel Tank Capacity	4 gal / 15.5 L
AC Motor	120V AC / 60 HZ
Optional: Lithium Ion Battery	64 V / 120 Ah
Optional: Bi-Energy	Kubota Diesel + Lithium Ion Battery

Tracks

Standard	Non-marking Tracks
----------	--------------------

Hydraulic System

Capacity	10.56 gal / 40 L
----------	------------------

STANDARD FEATURES

- 110V-AC receptacle at Platform
- Air/Water Line to Platform
- Caster Platform Wheels
- Color Remote and Ground Panel Provides On-board Diagnostics
- Control Box with New Color Display
- Electric Controls With One-Touch Outrigger Deployment, Stowage & Leveling
- Flashing Amber Beacon
- Fork Pockets and Lifting Points
- Large Teflon® Outrigger Pads
- Load Sensing System
- Non-Marking Tracks
- On Board Battery Heaters
- Patented Quick Disconnect Two-Person Platform with Dual Side Entry
- Powered Track Widening
- SkyGuard SkyLine™
- Synthetic Biodegradable Hydraulic Oil



866 874-0584 AERIALTITANS.COM

X540AJ

COMPACT CRAWLER

BOOM LIFT



AERIAL TITANS

DIMENSIONS

All dimensions are approximate

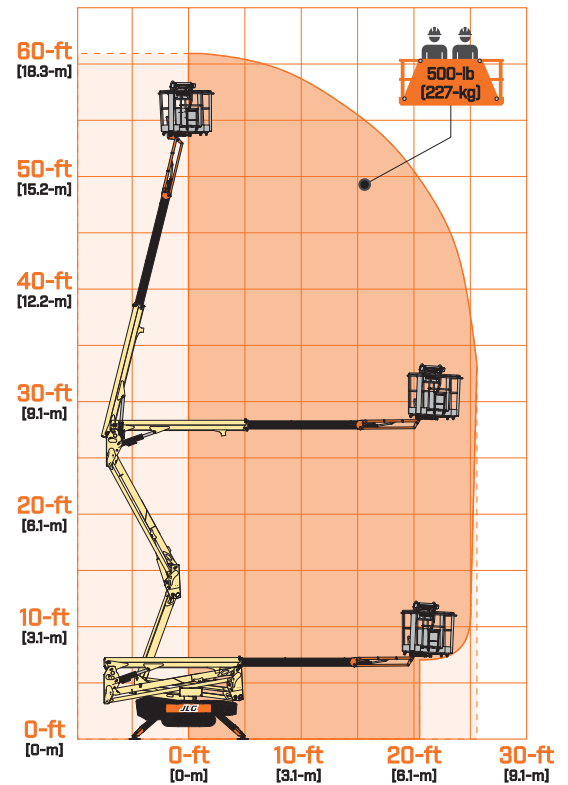
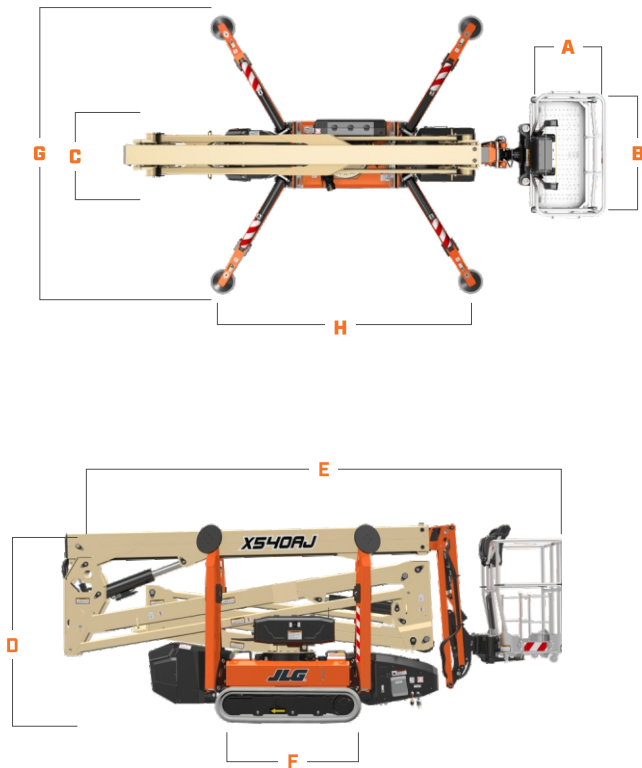

A. Platform Width	30.4-in / .77-m
B. Platform Length	55-in / 1.4-m
C. Machine Width with Platform	55-in / 1.4-m
Machine Width without Platform Tracks Retracted	31.3-in / .8-m
Machine Width without Platform Tracks Extended	43.1-in / 1.1-m
D. Machine Height	6-ft 7-in / 1.99-m
E. Machine Length	16-ft 7-in / 5.1-m
Machine Length Without Platform	14-ft 6-in / 4.4-m
F. Track length	4-ft 10-in / 1.5-m
G. Outrigger Footprint Length	9-ft 7-in / 2.9-m
H. Outrigger Footprint Width	9-ft 7-in / 2.9-m
Outrigger Pad Diameter	11.8-in / 30-cm

Images for reference only



We provide coverage for one (1) full year, and cover all specified major structural components for five (5) years. Due to continuous product improvements, we reserve the right to make specification and/or equipment changes without prior notification. This machine meets or exceeds applicable ANSI and CSA requirements based on machine configuration as originally manufactured for intended applications. Please reference the serial number plate on the machine for additional information.



866 874-0584 AERIALTITANS.COM



JLG INDUSTRIES, INC.
Toll-free US 877-JLG-LIFT
JLG.com

An Oshkosh Corporation Business