

# ES1930M

MICRO-SIZED ELECTRIC SCISSOR LIFT

SCISSOR LIFT



## AERIAL TITANS



### KEY SPECS

#### Max Platform Height

18-ft 6-in / 5.64-m

#### Platform Capacity

500-lb / 227-kg

#### Number of Occupants

Indoor: 2\*  
Outdoor: 1

#### Stowed Drive Speed

3.0 mph / 4.8 km/h

### KEY FEATURES

- Access tight spaces with fixed rails that fit through doorways while experiencing exceptional maneuverability featuring a **zero turn radius**, compact footprint with **narrowest width** in the market and low overall stowed height – all with a platform height of 18-ft 6-in.
- Protect delicate work surfaces with the **standard leak containment system** consisting of custom-fit trays to capture potential leaks.
- Maximize productivity and uptime with **greater duty cycles** versus the market leader and **onboard technology** exclusive to JLG including Variable Tilt and ClearSky Smart Fleet.
- Optimize versatility with the ability to configure the machine with an **integrated mid-rail deck**, offering an **additional 19.5-in height** in the platform.

### ACCESSORIES & OPTIONS

- 2 x 12V 115 amp-hr AGM
- 900W Inverter
- Additional Single Amber Beacon
- Anti-Vandalism Package
- Coiled Platform Control Box Cable
- Hostile Environment Package
- Integrated Mid-Rail Deck (Additional 19.5-in Height)
- MDI (Ground)
- Special Hydraulic Fluids
- White Noise Alarm

\*When optional mid-rail deck is in use, only one occupant.

### STANDARD SPECIFICATIONS

Performance	Indoor	Outdoor
Platform Height (Elevated)	18-ft 6-in / 5.64-m	15-ft / 4.57-m
Platform Capacity	500-lb / 227-kg	500-lb / 227-kg
Capacity on Platform Extension	254-lb / 115-kg	254-lb / 115-kg
Number of Occupants	2	1
Lift / Lower Time (No Load)	22-27 Seconds	22-27 Seconds
Lift / Lower Time (Rated Load)	25-26 Seconds	25-26 Seconds
Maximum Drive Height	Fully Elevated	15-ft / 4.57-m
Weight*	2,978-lb / 1,351-kg	2,978-lb / 1,351-kg
Max. Ground Bearing Pressure	170 psi / 11.95 kg/cm <sup>2</sup>	170 psi / 11.95 kg/cm <sup>2</sup>
Drive Speed (Lowered)	3.0 mph / 4.8 km/h	3.0 mph / 4.8 km/h
Drive Speed (Raised)	0.5 mph / 0.8 km/h	0.5 mph / 0.8 km/h
Max Gradeability	24%	24%
Max Tilt Rating (Side-to-Side)	1.5 Degrees	1.5 Degrees
Max Tilt Rating (Fore and Aft)	3.0 Degrees	3.0 Degrees
Turning Radius (Inside)	Zero	Zero
Turning Radius (Outside)	55-in / 1.40-m	55-in / 1.40-m

\*Certain options or country standards increase weight

### Power

Batteries	2x 12V 130 amp-hr
Charger	650 W Delta-Q
Drive	24V DC

### Tires

Standard	10 x 3-in / 250 x 70-mm, Non-marking
----------	--------------------------------------

### Brakes

Multi-Disc Friction

### Hydraulic System

Capacity	1 gal / 3.8L
Pump	Fixed Displacement Gear

### STANDARD FEATURES

- 27 amp Multi-Function Universal Charger
- 110v AC Receptacle in Platform
- Active Pothole Protection System
- All Motion Alarm
- Analyzer Port for Diagnostics
- Battery Condition Indicator
- CAN-Enabled Charger
- ClearSky Smart Fleet™ Hardware (CS550)
- Diamond Tread Steel Deck
- Drive Motor Covers
- Electric Drive
- Fixed rails
- Foot-Actuated Deck Extension
- Fork Lift Pockets
- Greaseless Kingpin Joints
- Horn
- Hourmeter
- Lanyard Attach Points
- Leak Containment System
- LED Motion/Amber Beacon (CS550)
- Lifting and Tie Down Points
- Load Sensing System
- Lubrication Free Scissor Arm Bushings
- Manual Descent Cable
- Movable, Removable Platform Control
- Nickel Plated Pins
- Proportional Controls
- Removable Ladder
- Scissor Maintenance Prop
- Self-Closing Gate
- Steel Swing-Out Doors
- Tilt Alarm and Light
- USB Charger & Phone Holder
- Variable Tilt Visual Zone Indicator



866 874-0584 AERIALTITANS.COM

# ES1930M

MICRO-SIZED ELECTRIC SCISSOR LIFT

SCISSOR LIFT



## AERIAL TITANS

### DIMENSIONS

All dimensions are approximate

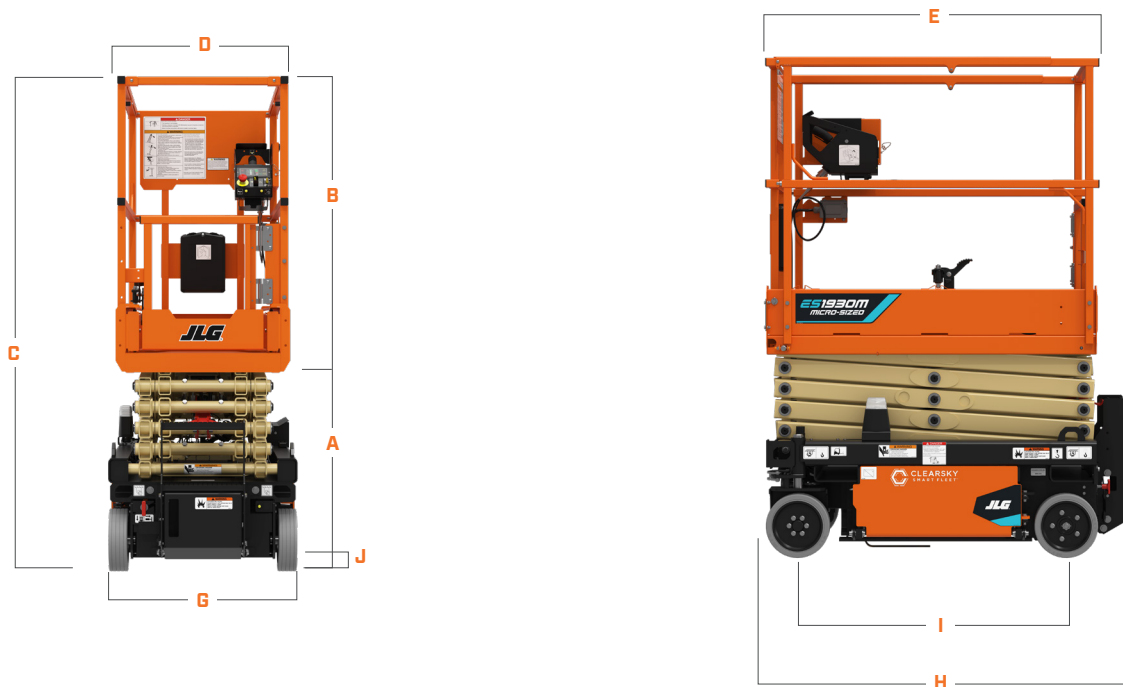

A. Platform Height (Lowered)	34.2-in / 87-cm
B. Platform Railing Height	43.8-in / 1.10-m
C. Machine Height (Rails Raised)	78.1-in / 1.98-m
D. Platform Width	27.6-in / 70-cm
E. Platform Length	52.8-in / 1.34-m
Platform Extension	21.6-in / 55-cm

G. Machine Width	30-in / 76-cm
H. Machine Length	57.8-in / 1.47-m
I. Wheelbase	42.3-in / 1.07-m
J. Ground Clearance	2.4-in / 6-cm



866 874-0584 AERIALTITANS.COM



We provide coverage for one (1) full year, and cover all specified major structural components for five (5) years. Due to continuous product improvements, we reserve the right to make specification and/or equipment changes without prior notification. This machine meets or exceeds applicable ANSI and CSA requirements based on machine configuration as originally manufactured for intended applications. Please reference the serial number plate on the machine for additional information.



JLG INDUSTRIES, INC.  
Toll-free US 877-JLG-LIFT  
JLG.com

An Oshkosh Corporation Business