

800S

TELESCOPIC BOOM LIFT

BOOM LIFT



AERIAL TITANS



STANDARD SPECIFICATIONS

Performance

Platform Height (Elevated)	80-ft / 24.38-m
Horizontal Outreach	71-ft / 21.64-m
Swing	360 Degrees Continuous
Platform Capacity (Restricted)	1,000-lb / 454-kg
Platform Capacity (Unrestricted)	500-lb / 227-kg
Platform Rotator	180 Degrees Hydraulic
Weight*	34,150-lb / 15,490-kg
Max. Ground Bearing Pressure	72 psi / 5.06 kg/cm ²
Drive Speed	3.5 mph / 5.6 km/h
Gradeability 2WD	25%
Gradeability 4WD	45%
Tilt Cut Out	4 Degrees
Turning Radius (Inside)	12-ft 6-in / 3.8-m
Turning Radius (Outside)	19-ft 8-in / 6.02-m

Engine

Dual Fuel – Ford-MSG425-DF	84 hp / 62.6 kW
Diesel Fuel – Deutz D2.9L4 Tier 4 Final	67 hp / 50 kW
Fuel Tank Capacity	31 gal / 117.35 L

Tires

Standard	Foam Filled, 15-625(24.5)
Optional	Foam Filled Non-Marking, 18-625 Foam Filled, 18-625(24.5) Foam Filled, Turf & Sand, 41x18LLx22.5

Hydraulic System

Capacity	48 gal / 181.7 L
Pump	Fixed Displacement Gear

STANDARD FEATURES

- 4 Degree Tilt Alarm / Indicator Light
- 12V-DC Auxiliary Power
- 110V-AC Receptacle in the Platform
- 180 Degree Hydraulic Platform Rotator
- ClearSky Smart Fleet™ Hardware (CS550)
- Control ADE® System
- Glow Plugs (Diesel Engines)
- Horn
- Hourmeter
- Hydrostatic Drive
- Improved Multi-Function Controls
- Interactive Display at Ground Controls
- LED Motion / Amber Beacon (CS550)
- Lifting / Tie Down Lugs
- Motion Alarm
- Oscillating Axle
- Platform Console Machine Status Light Panel**
- Proportional Controls
- SkyGuard SkyLine™
- Swing-Out Engine Tray

*Certain Options or Country Standards Increase Weight.

**Provides Indicator Lights at Platform Control Console for System Distress, Low Fuel, Degree Tilt Light and Foot Switch Status.

1. Includes arctic hydraulic hoses (drive and steer only) and main boom cable, arctic hydraulic oil, extreme cold engine oil, fuel conditioner, engine block heater, battery blanket, glow plugs, hydraulic tank heater, and oversized footswitch.
2. Includes battery blanket, hydraulic tank heater, block heater.
3. Includes console cover, boom wipers and cylinder bellows.

Note: Some options may increase lead time, and some option combinations may not be available. Additional accessories and options available via JLG Aftermarket.

KEY SPECS

Platform Height 80-ft / 24.38-m	Horizontal Outreach 71-ft / 21.64-m
Drive Speed 3.5 mph / 5.6 km/h	Platform Capacity Restricted: 1,000-lb / 454-kg Unrestricted: 500-lb / 227-kg

KEY FEATURES

- Optimize productivity by reaching full elevation in less than 70 seconds.
- Utilizes the JLG Advanced Design Electronics System that reduces costs by increasing fuel efficiency while also reducing emissions.
- Delivers a zero calibration automatic load sensing system that eliminates the need to use external weights to calibrate the machine.
- Available accessories and options provide the flexibility to upfit the machine to meet unique job requirements.

ACCESSORIES & OPTIONS

- 1/2-in Air Line to Platform
- AC Generator, 2500W or 4000W
- Accessory Packages
 - SkyGlazier® Package
 - SkyPower® Package
 - SkyWelder® Package
- Arctic Package¹
- Bolt On Fall Arrest System
- Cold Weather Package²
- Hostile Environment Package³
- Light Package
- Platform Mesh to Mid or Top Rail
 - Aluminum or Plastic
- Platforms
 - Drop Bar, 30 x 36-in, 30 x 48-in, 30 x 60-in, 36 x 72-in, 36 x 96-in
 - Fall Arrest, Rear Entry, 36 x 72-in, 36 x 96-in
 - Inward Self-Closing Swing Gate, 30 x 48-in, 30 x 60-in, 36 x 72-in, 36 x 96-in
- Tri-Entry, Drop Bar or Swing Gate, 36 x 72-in, 36 x 96-in
- SkySense® Enhanced Detection System
- Soft Touch System
- Storage Tray - Center or Corner



866 874-0584 AERIALTITANS.COM

800S

TELESCOPIC BOOM LIFT

BOOM LIFT



AERIAL TITANS

DIMENSIONS

All dimensions are approximate

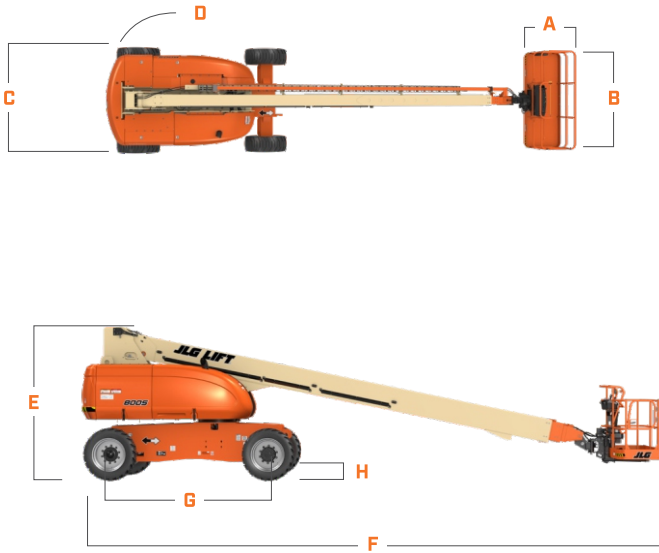

A. Platform Width	36-in / 91-cm
B. Platform Length	96-in / 2.44-m
C. Machine Width	8-ft 2-in / 2.49-m
D. Tailswing	4-ft 8-in / 1.42-m
E. Machine Height	9-ft 8.1-in / 2.95-m
F. Machine Length	37-ft 5.9-in / 11.43-m
G. Wheelbase	10-ft / 3.05-m
H. Ground Clearance	11-in / 28-cm

REACH DIAGRAMS

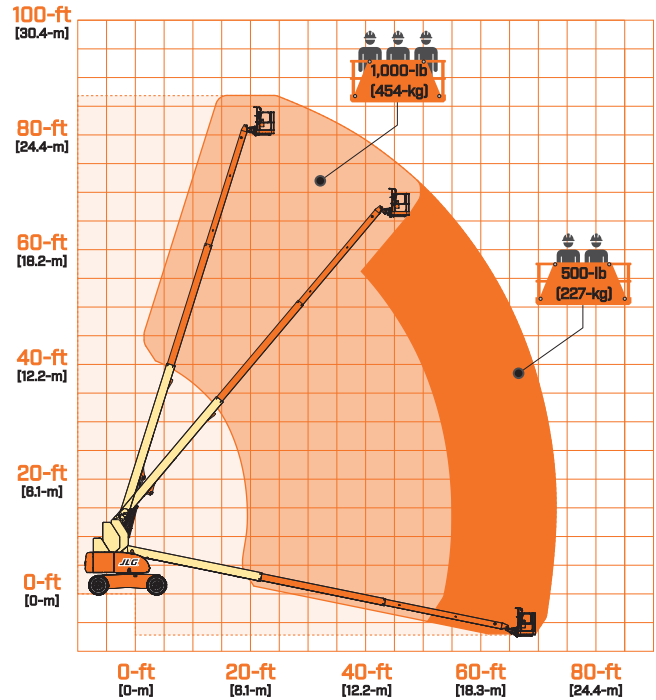

AERIAL TITANS

866 874-0584 AERIALTITANS.COM



We provide coverage for one (1) full year, and cover all specified-major structural components for five (5) years. Due to continuous product improvements, we reserve the right to-make specification and/or equipment changes without prior notification. This-machine-meets or exceeds applicable ANSI and CSA requirements based on-machine configuration as originally-manufactured for intended applications. Please reference the serial number plate on the-machine for additional information.



JLG INDUSTRIES, INC.
Toll-free US 877-JLG-LIFT
JLG.com

An Oshkosh Corporation Company