

670SJ

SELF-LEVELING TELESCOPIC BOOM LIFT

BOOM LIFT



AERIAL TITANS



KEY SPECS

Platform Height
66-ft 10-in / 20.36-m

Drive Speed
3.8 mph / 6.1 km/h

Horizontal Outreach
57-ft 1-in / 17.40-m

Platform Capacity
Restricted: 750-lb / 340-kg
Unrestricted: 550-lb / 250-kg

KEY FEATURES

- Get right to work with smart-adapting technology to level on slopes up to 10 degrees, while driving at full height.
- Remove the need for cribbing or grading the job site, trial-and-error positioning or use of larger equipment to reach over uneven terrain.
- Less bouncing around in the platform helps operators feel less fatigued and less distracted by tools shifting in transit.
- A fully integrated advanced control system provides real-time data right on the job site.

ACCESSORIES & OPTIONS

- 1/2-in Air Line to Platform
- AC Generator, 2500W or 4000W
- Accessory Packages
 - SkyGlazier® Package
 - SkyPower® Package
 - SkyWelder® Package
- Arctic Package¹
- Bolt On Fall Arrest System
- Cold Weather Package²
- Light Package
- Platform Mesh to Mid or Top Rail
 - Aluminum or Plastic
- Platforms
 - Drop Bar, 30 x 36-in, 30 x 60-in, 36 x 72-in, 36 x 96-in
 - Fall Arrest, Rear Entry, 36 x 72-in, 36 x 96-in
 - Inward Self-Closing Swing Gate, 30 x 60-in, 36 x 72-in, 36 x 96-in
- Tri-Entry, Drop Bar or Swing Gate, 36 x 72-in, 36 x 96-in
- SkySense® Enhanced Detection System
- Soft Touch System
- Storage Tray - Center or Corner

STANDARD SPECIFICATIONS

Performance

Platform Height	66-ft 10-in / 20.36-m
Horizontal Outreach	57-ft 1-in / 17.40-m
Swing	360 Degrees Continuous
Tailswing	4-ft / 1.22-m
Platform Capacity (Restricted)	750-lb / 340-kg
Platform Capacity (Unrestricted)	550-lb / 250-kg
Platform Rotator	180 Degrees Hydraulic
Jib Length	6-ft / 1.83-m
Jib Range of Articulation	132 Degrees (+71, -61)
Weight*	25,341-lb / 11,494-kg
Max. Ground Bearing Pressure	85 psi / 5.87 kg/cm ²
Drive Speed 4WD	3.8 mph / 6.1 km/h
Gradeability 4WD	45%
Leveling Capacity (Fore/Aft)	10 Degrees
Leveling Capacity (Side to side)	10 Degrees
Turning Radius (Inside/Outside)	Inside: 8-ft 4.4-in / 2.55-m Outside: 18-ft 7.6-in / 5.68-m

Engine

Diesel Engine – Deutz T4F	67 hp / 50 kW
Fuel Tank Capacity	31 gal / 117 L

Tires

Standard	Foam Filled, 14(IN355)x17.5(55D625)
Optional	Foam Filled Non-Marking, 14(IN355)x17.5(55D625)

Hydraulic System

Capacity	34 gal / 129 L
Auxiliary Power	12V DC

STANDARD FEATURES

- 10 Degree slope leveling capability
- 12V-DC Auxiliary Power
- 110V-AC Receptacle in the Platform
- 180 Degree Hydraulic Platform Rotator
- ClearSky Smart Fleet™ Hardware (CS550)**
- Control ADE® System
- Four-Wheel Hydrostatic Drive
- Glow Plugs (Diesel Engines)
- Horn
- Hourmeter
- Improved Multi-Function Controls
- Interactive Display at Ground Controls
- LED Motion / Amber Beacon (CS550)**
- Lifting / Tie Down Lugs
- Motion Alarm
- Oscillating Axle
- Platform Console Machine Status Light Panel***
- Proportional Controls
- SkyGuard SkyLine™
- Swing-Out Engine Tray

*Certain Options or Country Standards Increase Weight.

**Standard Beacon and ClearSky Smart Fleet Hardware Availability Varies by Model Throughout 2023.

***Provides Indicator Lights at Platform Control Console for System Distress, Low Fuel, Degree Tilt Light and Foot Switch Status.

1. Includes arctic hydraulic hoses (drive and steer only) and main boom cable, arctic hydraulic oil, extreme cold engine oil, fuel conditioner, engine block heater, battery blanket, glow plugs, hydraulic tank heater, and oversized footswitch.
2. Includes battery blanket, hydraulic tank heater, block heater.

Note: Some options may increase lead time, and some option combinations may not be available. Additional accessories and options available via JLG Aftermarket.

Due to continuous improvement, we reserve the right to make specification and/or equipment changes without prior notification.

670SJ

SELF-LEVELING TELESCOPIC BOOM LIFT

BOOM LIFT



AERIAL TITANS

DIMENSIONS

All dimensions are approximate

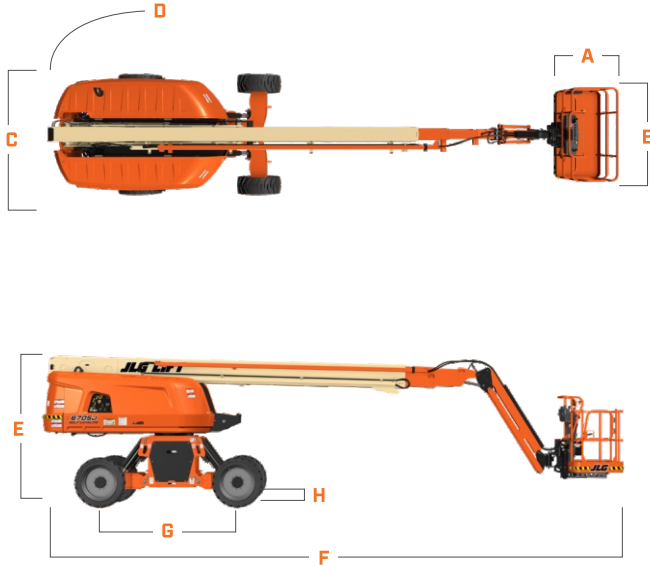

- A. Platform Width 36-in / 0.91-m
- B. Platform Length 96-in / 2.44-m
- C. Machine Width 8-ft 2.4-in / 2.50-m
- D. Tailswing 4-ft / 1.22-m
- E. Machine Height 9-ft 1.2-in / 2.74-m
- F. Machine Length 35-ft 5-in / 10.68-m
- G. Wheelbase 8-ft 9.9-in / 2.69-m
- H. Ground Clearance 13-in / 33-cm

REACH DIAGRAM

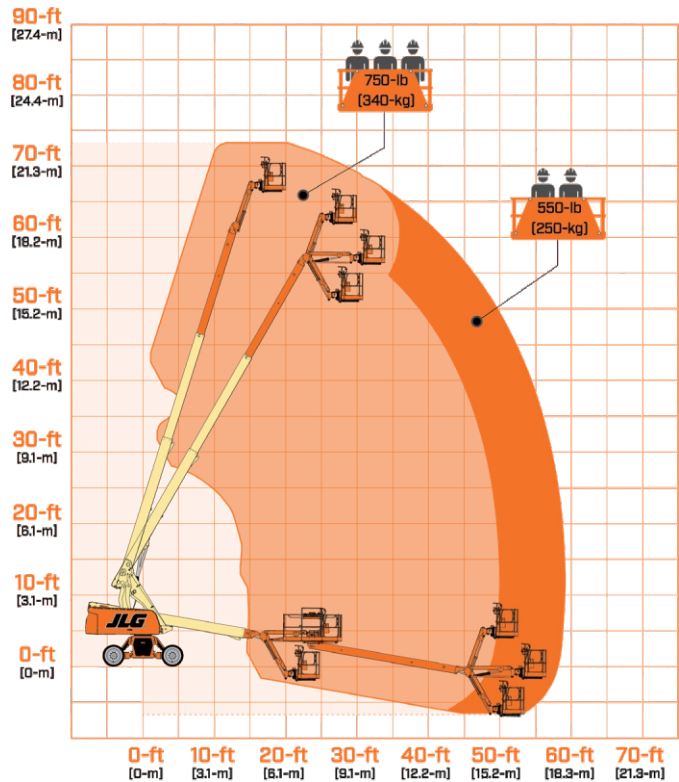

AERIAL TITANS

866 874-0584 AERIALTITANS.COM



We provide coverage for one (1) full year, and cover all specified-major structural components for five (5) years. Due to continuous product improvements, we reserve the right to make specification and/or equipment changes without prior notification. This-machine-meets or exceeds applicable ANSI and CSA requirements based on-machine configuration as originally-manufactured for intended applications. Please reference the serial number plate on the-machine for additional information.



JLG INDUSTRIES, INC.
Toll-free US 877-JLG-LIFT
JLG.com

An Oshkosh Corporation Company