

# AERIAL TITANS

## STATIC DIMENSIONS

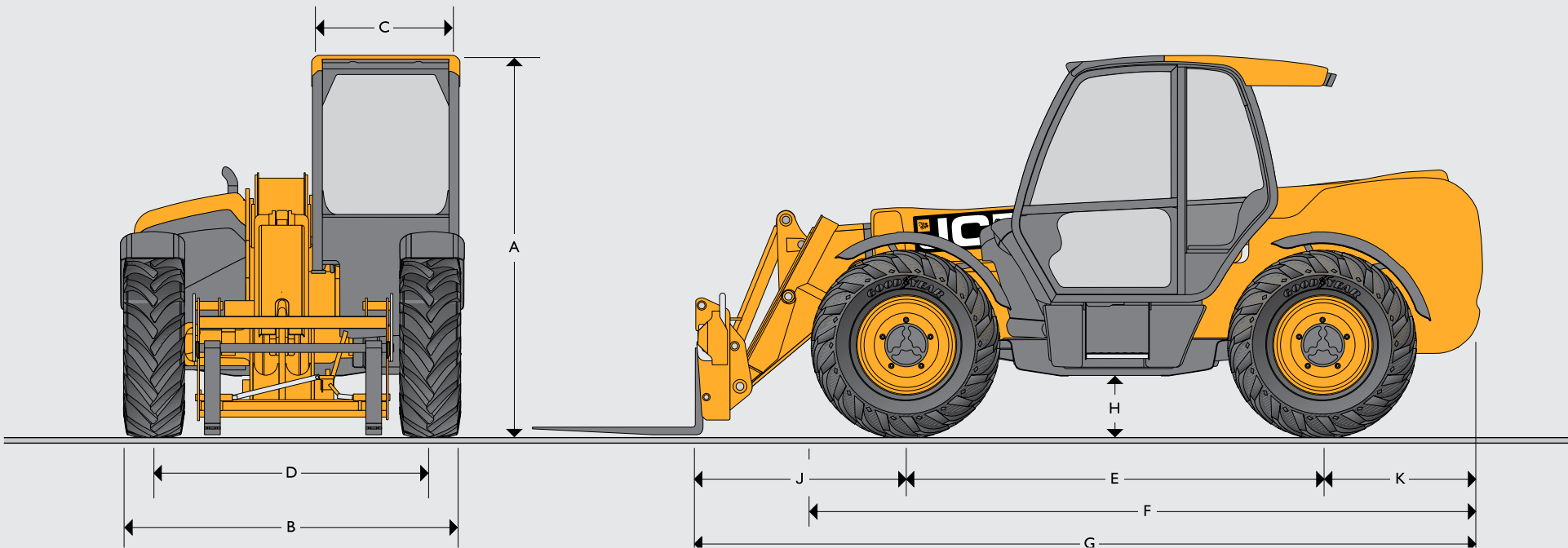

## STATIC DIMENSIONS

Machine model		506-23 TC	509-23 TC	512-26 TC	509-45TC	510-55 TC	508-66 TC
A Overall height	ft-in (m)	8-2 (2.49)	8-2 (2.49)	8-6 (2.59)	8-6 (2.59)	8-10 (2.69)	8-11 (2.72)
B Overall width (over tires)*	ft-in (m)	7-4 (2.23)	7-4 (2.23)	8-4 (2.54)	7-8 (2.35)	8-0 (2.44)	8-0 (2.44)
C Inside width of cab	ft-in (m)	3-1 (0.94)	3-1 (0.94)	3-1 (940)	3-1 (940)	3-1 (0.94)	3-1 (940)
D Front track	ft-in (m)	5-11 (1.81)	5-11 (1.81)	6-6 (1.98)	6-2 (1.90)	6-3 (1.9)	6-5 (1.97)
E Wheelbase	ft-in (m)	9-0 (2.75)	9-0 (2.75)	9-0 (2.75)	9-0 (2.75)	9-0 (2.75)	9-0 (2.75)
F Overall length to front tires	ft-in (m)	14-4 (4.38)	14-4 (4.38)	14-6 (4.42)	15-6 (4.74)	16-8 (5.08)	16-8 (5.09)
G Overall length to front carriage	ft-in (m)	16-4 (4.99)	16-4 (4.99)	17-3 (5.27)	20-5 (6.23)	20-10 (6.36)	22-4 (6.81)
H Ground clearance	ft-in (m)	1-4 (0.4)	1-4 (0.4)	1-3 (400)	1-3 (400)	1-4 (0.4)	1-4 (410)
J Front wheel center to carriage	ft-in (m)	4-1 (1.25)	4-1 (1.25)	-	6-11 (2.11)	6-3 (1.94)	7-10 (2.39)
K Rear wheel center to rear face	ft-in (m)	3-2 (0.99)	3-2 (0.99)	-	4-5 (1.37)	5-4 (1.67)	7-10 (2.39)
Overall width with stabilizers fully deployed	ft-in (m)	N/A	N/A	NA	8-5 (2.57)	11-6 (3.55)	12-6 (3.82)
Outside turn radius (over tires)	ft-in (m)	12-2 (3.7)	12-2 (3.7)	13-5 (4.10)	12-3(3.75)	13-5 (4.1)	13-5 (4.1)
Carriage rollback angle	degrees	42.6	42.6	47	37	39	39
Carriage dump angle	degrees	37.5	33.0	33.0	12.5	8.8	8.8
Weight	lb (kg)	15560 (7060)	17306 (7850)	24340 (11040)	23986 (10880)	27494 (12470)	28627 (12985)
Tires		15.5/80-24	15.5/80-24	480/80 R26	15.5/80-24	17.5-25 16 PR	17.5-25

\* Dependent upon tire specified

# AERIAL TITANS

## LIFT PERFORMANCE

		506-23 TC	509-23 TC	512-26 TC	509-45 TC Stabilizers retracted	509-45 TC HiViz Stabilizers extended
Maximum lift capacity	lb (kg)	6000 (2722)	9000 (4090)	12000 (6000)	9000 (4082)	9000 (4082)
Lift capacity to full height	lb (kg)	6000 (2722)	5250 (2382)	6000 (2721)	3300 (1500)	7,000 (3175)
Lift capacity at full reach	lb (kg)	3000 (1250)	3,400 (1542)	3800 (1750)	500 (227)	2000 (907)
Lift height	ft-in (m)	23-0 (7)	23-0 (7)	26-6 (7.9)	45-2 (13780)	45-2 (13780)
Reach at maximum lift height	ft-in (m)	2-0 (0.61)	2-0 (0.61)	3-0 (0.92)	10-1 (3090)	10-1 (3090)
Maximum forward reach	ft-in (m)	12-2 (3.7)	12-2 (3.7)	14-8 (4.47)	31-9 (9700)	31-9 (9700)
Reach with 1 ton load	ft-in (m)	12-2 (3.7)	12-2 (3.7)	-	-	-
Placing height	ft-in (m)	20-6 (6.3)	20-6 (6.3)	-	-	-
Frame Sway	degrees	9°	9°	9°	9°	9°

## LIFT PERFORMANCE

		510-55 TC Stabilizers retracted	510-55 TC Stabilizers extended	508-66 TC Stabilizers retracted	508-66 TC Stabilizers extended
Maximum lift capacity	lb (kg)	10000 (4535)	10000 (4535)	8500 (3855)	8500 (3855)
Lift capacity to full height	lb (kg)	3000 (1361)	5000 (2269)	1100 (500)	3300 (1500)
Lift capacity at full reach	lb (kg)	0 (0)	1000 (453)	0 (0)	400 (181)
Lift height	ft-in (m)	42-10 (13.06)	54-9 (16.7)	32-8 (10.0)	65-7 (20)
Reach at maximum lift height	ft-in (m)	7-0 (2.13)	6-8 (2.03)	21-0 (6.4)	21-0 (6.4)
Maximum forward reach	ft-in (m)	30-0 (9.14)	41-5 (12.6)	31-8 (9.7)	52-1 (15.9)
Reach with 1 ton load	ft-in (m)	18-8 (5.76)	34-4 (10.5)	-	-
Placing height	ft-in (m)	35-9 (10.9)	53-2 (16.2)	-	-

\*Load charts are graphic representations, please consult technical load charts for full details.

# AERIAL TITANS

## ENGINE JCB EcoMAX

Latest technology and advanced design provides low fuel consumption, reduced noise, high torque and power output, total reliability and minimal maintenance.

Two-stage, dry type air filter with primary and safety elements. EPA Stage IV / Tier 4 emissions compliant.

## ENGINE

Machine model	506-23 TC/508-66 TC	506-23S TC/509-23S TC/509-45 TC/510-55 TC	512-26 TC
Emissions level	Stage IV / Tier 4	Stage IV / Tier 4	Stage IV/Tier 4
Manufacturer	JCB	JCB	JCB
Displacement liters	4.4	4.4	4.4
No. of cylinders	4	4	4
Bore size in (mm)	4.05 (103)	4.05 (103)	4.05 (103)
Stroke in (mm)	5.0 (132)	5.0 (132)	5.0 (132)
Aspiration	Turbocharged cooled	Turbocharged cooled & Intercooler	Turbocharged cooled
<b>Power rating</b>	r		
Power @ 2200rpm hp (kW)	74 (55)	109 (81)	125 (93)
<b>Torque rating</b>			
Torque @ 1300rpm Nm	400	516	550
After treatment	N/A	SCR & DEF	SCR & DEF

## HYDRAULIC CYCLE TIMES

	506-23 TC	509-23 TC	509-45 TC	512-26 TC	510-55 TC	508-66 TC
Lift seconds	7.2	8.8	13.5	7.4	22.7	17.3
Lower seconds	5.4	6.5	11	8.3	23.4	15.9
Extend seconds	6.8	6.8	15.6	8.3	18.3	28.1
Retract seconds	5	5	14.4	5.9	16.7	22.7
Bucket dump seconds	3.5	3.5	1.7	2.8	4.2	6.1
Bucket crowd seconds	2.9	2.9	2	3	4.6	5.9

## HYDRAULICS

	Hydraulic system pressure PSI (bar)	Max. pump flow gal/min (l/min)
506-23 TC	3500 (241)	21.6 (82)
509-23 TC	3770 (260)	23.2 (88)
512-26 TC	3770 (260)	37 (140)
509-45 TC	3770 (260)	29 (110)
510-55 TC	3770 (260)	43 (162)
508-66 TC	3770 (260)	29 (110)

## SERVICE CAPACITIES

Machine model	506-23 TC/509-45 TC/512-26 TC	509-45 TC	510-55 TC	508-66 TC
Coolant gallon (liters)	6 (23)	7 (28)	6 (23)	7 (28)
Engine oil sump gallon (liters)	3.6 (14)	4 (15)	3.6 (14)	4 (15)
Hydraulic oil gallon (liters)	29 (113)	35 (131)	40 (150)	48 (180)
Fuel tank gallon (liters)	38.5 (146)	38.5 (146)	38.5 (146)	38.5 (146)
DEF tank (model dependent) gallon (liters)	5.4 (20.8)	3 (13)	5.4 (20.8)	3 (13)

## TRANSMISSION

Torque converter, 4 speed powershift gearbox.

**Travel speed 512-26 TC:** 12mph

**Travel speed 506-23 TC / 509-23 TC:** 18mph, 20mph (when 2/4WD select is specified).

**Travel speed 509-45 TC / 510-55 TC / 508-66 TC:** 18mph.

## BRAKES

**Service brakes:** Hydraulically activated, self-adjusting, oil-immersed in-board high back-off multi-disc type on front axle.

**Parking brake:** Hand-operated disc brake on output of gearbox 74hp (55kW); Hand-operated disc brake on output of gearbox, 109hp (81kW) / 125hp (93kW); Oil immersed disc type.

## BOOM & CARRIAGE

Boom is manufactured from high tensile steel. JCB self-levelling carriage and pallet forks and a wide range of attachments.

## STEERING

Hydrostatic power steering with power track rods on both axles.

## SAFETY CHECK VALVES

Fitted to carriage tilt, telescopic and boom lift cylinders.

## STANDARD FEATURES

Cab Dash Instruments (Tachometer, Hourmeter, Fuel Gauge, Coolant Temp Gauge, DEF Gauge (when applicable)), Battery Isolator, Fenders (4), Joystick Lock, Back Up Alarm, Single Auxiliary Connection, Safety/Maintenance Strut, LiveLink Telematics (including subscription)

**Options:** Canopy or Cab, Air Conditioning, Air Suspension Seat, Front and Roof Guard, Radio Ready, Work Lights (Halogen or LED), Boom Lights (Halogen or LED), Road Lights, Rear and/or Side Cameras, Additional Mirrors, Hydraulic Attachment Locking, Engine Block Heater, Various Tires (Size, Tread, Type), Various Attachments for QFit Coupler

\*Option offering is model dependent and is subject to change; contact local JCB dealer for current offering and a quote.



**ONE COMPANY, OVER 300 MACHINES.**

For more information on this equipment  
please contact:

**CONSTRUCTION LOADALLS: TOOL CARRIER RANGE**

Gross power: 74hp / 55kW □ 125hp / 93kW    Lift capacity: 6,000 □ 12,000 lbs    Lift height: 23 □ 66

**JCB North America**

2000 Bamford Blvd., Pooler, Georgia, 31322 Tel: (912) 447-2000

Download the very latest information on this product range at [www.jcb.com](http://www.jcb.com)

JCB inc. All rights reserved. No part of this publication may be reproduced, stored in a retrieval system, or transmitted in any form or by any other means, electronic, mechanical, photocopying or otherwise, without prior permission from JCB inc. All references in this publication to operating weights, sizes, capacities and other performance measurements are provided for guidance only and may vary dependant upon the exact specification of machine. They should not therefore be relied upon in relation to suitability for a particular application. Guidance and advice should always be sought from your JCB Dealer. JCB reserves the right to change specifications without notice. Illustrations and specifications shown may include optional equipment and accessories. The JCB logo is a registered trademark of J C Bamford Excavators Ltd.

**AERIAL  
TITANS**

(866)874-0584    [AERIALTITANS.COM](http://AERIALTITANS.COM)

 [JCBNA](https://www.facebook.com/JCBNA)
 [@JCBNA](https://twitter.com/JCBNA)
 [JCBNORTHAMERICA](https://www.youtube.com/JCBNORTHAMERICA)
 [JCBNA](https://www.instagram.com/JCBNA)

