



CONSTRUCTION LIFT AND PLACE | LOADALLS

506-36 / 507-42 / 509-42 / 510-42 / 510-56 / 512-56 / 514-56

Gross power: 74 hp / 55 kW – 109 hp / 81 kW | Lift capacity: 6,000 lb – 14,000 lb | Lift height: 36'4" – 56'

 **AERIAL TITANS**

 **JCB**

STATIC DIMENSIONS

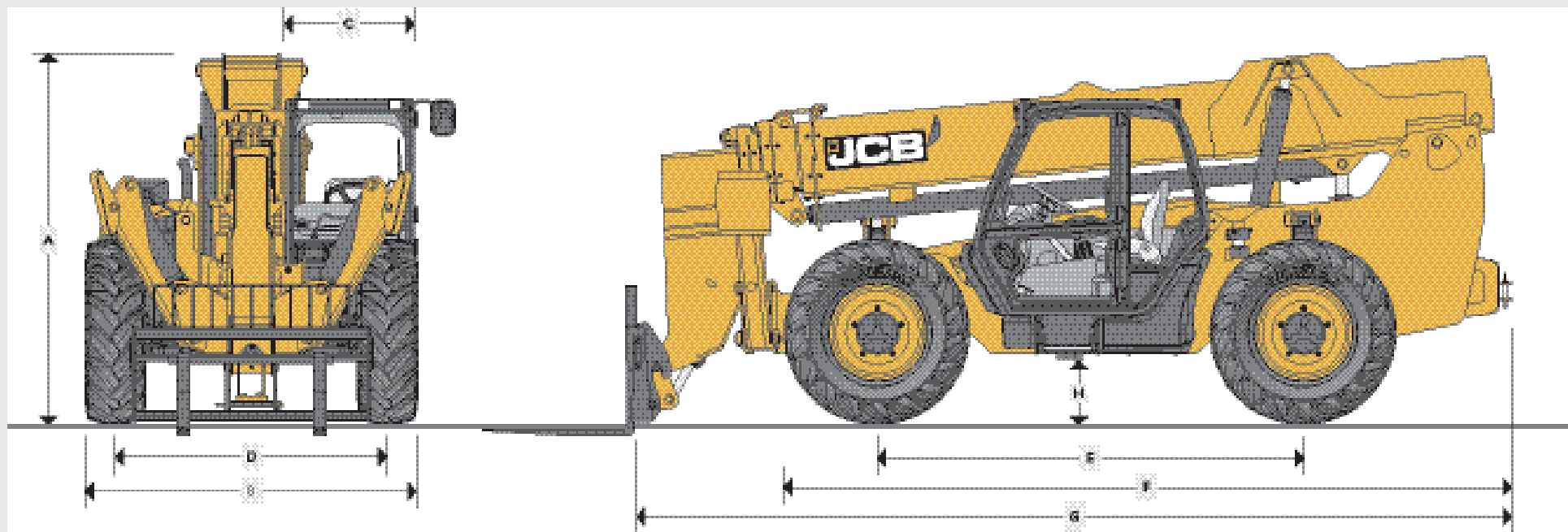
AERIAL TITANS

Machine model		506-36	507-42	509-42	510-42	510-56	512-56	514-56
A Overall height	ft-in (mm)	8-3 (2,510)	8-3 (2,525)	8-3 (2,525)	8-3 (2,525)	8-10 (2,692)	8-10 (2,692)	8-11 (2,716)
B Overall width (over tires)	ft-in (mm)	7-10 (2,388)	7-10 (2,388)	7-10 (2,388)	7-10 (2,388)	8-1 (2,471)	8-1 (2,471)	8-1 (2,475)
C Inside width of cab	ft-in (mm)	3-1 (940)	3-1 (940)	3-1 (940)	3-1 (940)	3-1 (940)	3-1 (940)	3-1 (940)
D Front track	ft-in (mm)	6-4 (1,936)	6-7 (2,008)	6-7 (2,008)	6-7 (2,008)	6-7 (2,008)	6-7 (2,008)	6-7 (2,008)
E Wheelbase	ft-in (mm)	10-4 (3,150)	10-4 (3,150)	10-4 (3,150)	10-4 (3,150)	10-4 (3,150)	10-4 (3,150)	10-4 (3,150)
F Overall length to front tires	ft-in (mm)	17-1 (5,211)	17-8 (5,386)	17-0 (5,183)	17-8 (5,385)	17-9 (5,406)	17-9 (5,406)	18-4 (5,596)
G Overall length to front carriage	ft-in (mm)	19-5 (5,918)	21-3 (6,477)	20-7 (6,274)	21-3 (6,477)	21-7 (6,579)	21-7 (6,579)	22-4 (6,815)
H Ground clearance	ft-in (mm)	1-3½ (396)	1-3½ (396)	1-3½ (396)	1-3½ (396)	1-5½ (444)	1-5½ (444)	1-5½ (444)
Outside turn radius (over tires)	ft-in (mm)	14-6 (4,420)	13-9 (4,191)	13-9 (4,191)	13-9 (4,191)	14-1 (4,293)	14-1 (4,293)	14-4 (4,365)
Weight	lb (kg)	20,270 (9,193)	21,300 (9,660)	22,430 (10,172)	23,858 (10,822)	29,900 (13,560)	30,635 (13,895)	32,143 (14,580)
Tires		13.00-24	14.00-24	14.00-24	14.00-24	17.5-25	17.5-25	17.5-25

AERIAL TITANS

LIFT PERFORMANCE

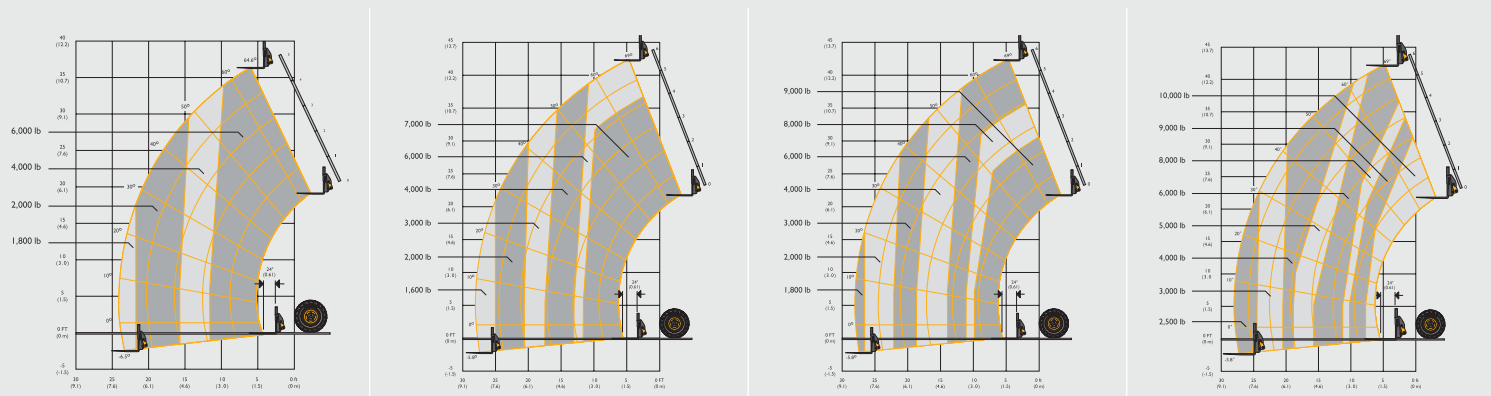

Machine model		506-36	507-42	509-42	510-42
Lift height	ft-in (mm)	36-4 (11,070)	42-0 (12,800)	42-0 (12,800)	42-0 (12,800)
Maximum lift capacity	lb (kg)	6,000 (2,722)	7,000 (3,175)	9,000 (4,084)	10,000 (4,537)
Lift capacity to full height (on tires)	lb (kg)	6,000 (2,722)	6,000 (2,722)	6,000 (2,722)	6,000 (2,722)
Lift capacity at full reach	lb (kg)	1,800 (816)	1,600 (725)	1,800 (816)	2,500 (1,133)
Reach at maximum lift height	ft-in (mm)	6-4 (1,930)	4-11 (1,500)	4-11 (1,500)	4-11 (1,500)
Maximum forward reach	ft-in (mm)	24-0 (7,310)	28-0 (8,530)	28-0 (8,530)	28-0 (8,530)
Frame sway left or right	degrees	10	10	10	10

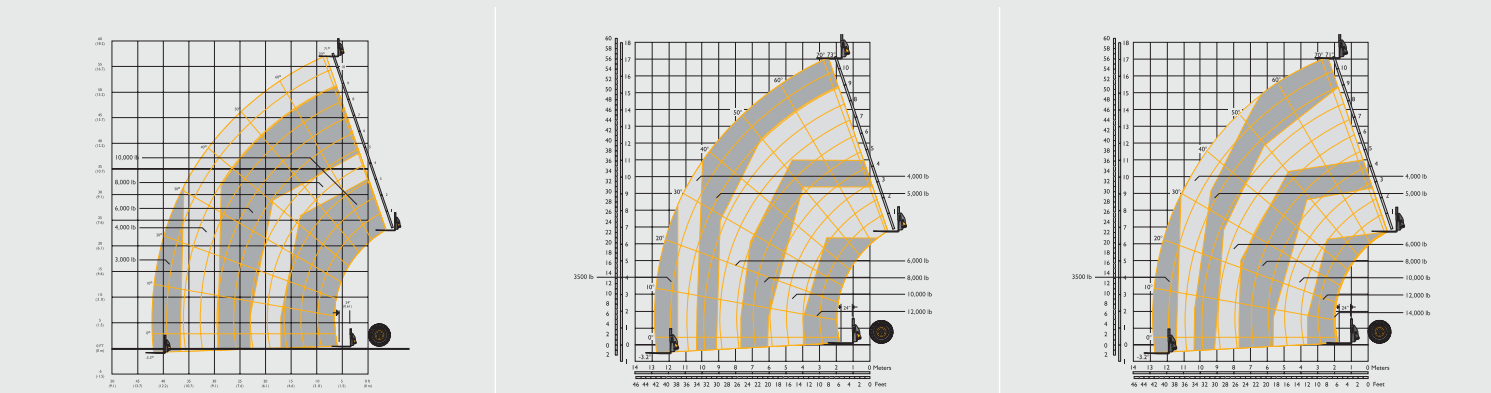

Machine model		510-56	512-56	514-56
Lift height	ft-in (mm)	56-0 (17,070)	56-0 (17,070)	56-0 (17,070)
Maximum lift capacity	lb (kg)	10,000 (4,537)	12,000 (5,444)	14,000 (6,350)
Lift capacity to full height (on tires)	lb (kg)	3,000 (1,361)	4,000 (1,814)	4,000 (1,814)
Lift capacity to full height (on stabilizers)	lb (kg)	4,000 (1,814)	5,000 (2,268)	5,000 (2,268)
Lift capacity at full reach (on tires)	lb (kg)	300 (136)	300 (136)	500 (227)
Lift capacity at full reach (on stabilizers)	lb (kg)	3,000 (1,360)	3,500 (1,587)	3,500 (1,587)
Reach at maximum lift height	ft-in (mm)	8-2 (2,490)	8-2 (2,490)	8-2 (2,490)
Maximum forward reach	ft-in (mm)	42-0 (12,800)	42-0 (12,800)	42-0 (12,800)
Frame sway left or right	degrees	10	10	10

*Load charts are graphic representations, please consult technical load charts for full details.

ENGINE			
Machine model		506-36 / 507-42 / 509-42 / 510-42 / 510-56 / 512-56	509-42 S / 510-42 S / 510-56 S / 512-56 S / 514-56 S
Emissions level		Tier 4	Tier 4
Manufacturer		JCB	JCB
Displacement	ltr	4.4	4.4
No. of cylinders		4	4
Bore size	in (mm)	4.05 (103)	4.05 (103)
Stroke	in (mm)	5.0 (132)	5.0 (132)
Aspiration		Turbocharged cooled & Intercooler	Turbocharged cooled & Intercooler
Power rating			
Power @ 2200 RPM	hp (kW)	74 (55)	109 (81)
Torque rating			
Torque @ 1300 RPM	Nm	400	504

SERVICE CAPACITIES		
Hydraulic tank	gallon (liters)	35 (132)
Coolant	gallon (liters)	6 (23)
Engine oil sump	gallon (liters)	3.6 (14)
Fuel tank	gallon (liters)	33.3 (126.3)

CYCLE TIMES								
Machine model		506-36	507-42	509-42	510-42	510-56	512-56	514-56
Lift	Seconds	11.2	11.7	13.8	13.8	18	18	16.8
Lower	Seconds	7.3	7.6	9.2	9.2	12.4	12.4	15.5
Extend	Seconds	8.5	9.7	9.7	9.7	24.2	24.2	22.7
Retract	Seconds	9.9	10.6	10.6	10.6	16.4	16.4	16.4
Bucket dump	Seconds	4	4	4	4	6.4	6.4	6.4
Bucket crowd	Seconds	3	3	3	3	3.7	3.7	4.5
Stabilizer down	Seconds	N/A	N/A	N/A	N/A	5.5	5.5	5.5
Stabilizer up	Seconds	N/A	N/A	N/A	N/A	4	4	4
Rear Axle Stabilization (RAS) System	Seconds	No	Yes	Yes	Yes	Yes	Yes	Yes

HYDRAULICS		
Two stage gear pump with suction strainer and filter		
Operating system pressure	psi (bar)	3,770 (260)
Main Hydraulics	gpm (lpm)	29 (110)
Auxiliary Flow	gpm (lpm)	16 (60)
TRANSMISSION	JCB powershift transmission incorporating torque converter, bevel box and a 4 speed powershift gearbox in one resiliently mounted unit. Front and rear drive axles: JCB epicyclic hub reduction drive/steer axles with Max-Trac torque proportioning differentials. Travel speed: 15.5 mph (25 kph).	
BRAKES	Service brakes: Hydraulically activated, self-adjusting, oil-immersed in-board high back-off multi-disc type on front axle. Parking brake: Hand-operated disc brake on output of gearbox (55 kW/74 hp, 81 kW/109 hp) – oil immersed disc type).	
BOOM AND CARRIAGE	Boom is manufactured from high tensile steel. JCB self-levelling carriage pallet forks and a wide range of attachments.	
ELECTRICS	12 V negative earth. 95 AH battery. 95 amp alternator.	
STEERING	Hydrostatic power steering with power track rods on both axles. Three steer mode options: front wheel steer; all wheel steer; crab steer: operated from in the cab by a selection lever.	
CAB	Quiet, safe and comfortable cab conforms to ROPS ISO 3471 and FOPS ISO 3449. Tinted glass all round with laminated front and roof screen. Roof bars, front, rear and roof screen wash/wipe and heater/screen demister. Audio-visual warning system for coolant temperature, water in fuel, engine oil pressure, air cleaner, battery charge, transmission oil temperature and pressure. Hour meter and road speed indicator. Engine temperature, fuel gauge and clock. Adjustable steering column with stalk bar powershift change and forward reverse shuttle. Throttle and brake pedal floor mounted. Adjustable suspension seat with adjacent park brake.	
OPTIONS AND ACCESSORIES	Front and rear working lights, rotating flashing beacon, road lights, non-marking, foam-filled, turf tires, windshield and roof guard, radio kit, air conditioning, and carriage options available – contact your local dealer.	