

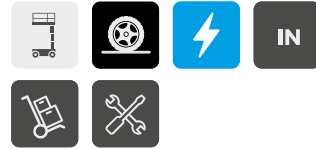

STAR 13 PICKING



OPTIMUM SAFETY AND PRODUCTIVITY

- > Dual side entry to the platform
- > Electric picking tray with foldable side panels and front guard rails
- > Quick, smooth, and precise driving
- > Open door interlock sensors

VERSATILITY

- > Maximum load of electric picking tray: 175 lbs
- > Ergonomically designed control panels with battery charge indicator in platform
- > Efficient transportation and lightning capabilities

THE BEST VALUE FOR THE MONEY

- > Haulotte Activ'Energy Management takes care of your batteries
- > 3-stage-cylinder mast with no chain or cable
- > Direct electric drive brushless AC motor
- > Easy access to components
- > Haulotte Activ'Screen (onboard diagnostics)



866 874-0584 AERIALTITANS.COM

STAR 13 PICKING

AERIAL TITANS

VERTICAL MASTS

TECHNICAL DATA

STAR 13 PICKING

Working height	18 ft 6 in
Platform height	12 ft 6 in
Lift capacity	463 lb (1 pers.)
Picking tray lift capacity	175 lb
A Length	5 ft 5 in
B Width	2 ft 7 in
C Height - stowed	5 ft 9 in
D Wheelbase	3 ft 6 in
E Ground clearance	2.3 in
Platform size	2 ft 6 in x 3 ft 0 in
Picking tray size	2 ft 5 in x 1 ft 8 in
Drive speed	0.5 - 2.8 mph
Turning radius - outside	5 ft 7 in
Tilt alarm	1.5 ° / 3 °
Gradeability	25 %
Driveable at full height up to	12 ft 6 in
Hydraulic tank capacity	2.1 gal
Tires	13 x 5 in
Batteries	4x6V - 180 Ah (C5)
Weight	1,962 lb

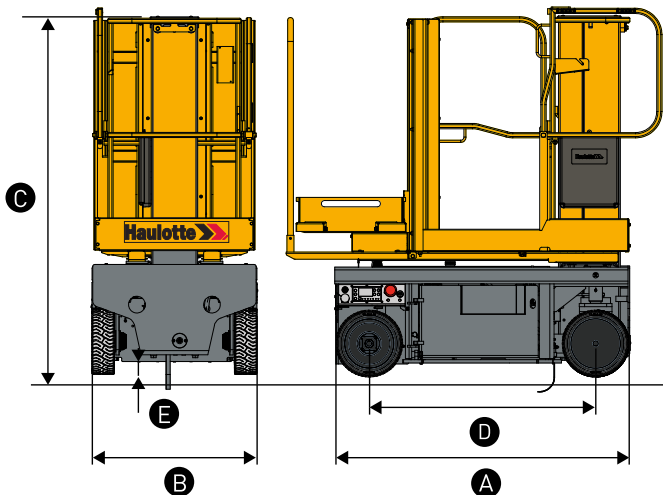

STANDARD EQUIPMENT

- > Haulotte Activ'Energy Management: Smart CAN charger
- > Electric picking tray with foldable side panels & front guard rails
- > 24 V electric drive brushless AC motors
- > 4 x 6 V - 180 Ah batteries
- > Battery charge indicator
- > Haulotte Activ'Screen
- > Fork lift pockets
- > Hoisting and lifting eyes
- > Brake release
- > Dual entry gates
- > Walkable protection plinths
- > Mobile pothole protection
- > 2 front steering wheels
- > 2 rear driving wheels
- > Non-marking tires
- > Hourmeter
- > Horn
- > Travel alarm
- > Flashing beacon
- > Emergency stop
- > Emergency hand pump
- > 2 upper control boxes (one is mobile)
- > Control stations at basket and ground levels
- > Towing hooks

OPTIONS AND ACCESSORIES

- > Haulotte Activ'Energy Management: automatic or manual battery waterfilling systems
- > Order / stock picker equipment
- > Biodegradable hydraulic oil
- > Cold temperature hydraulic oil
- > Telematics ready
- > Pedestrian warning light
- > Flashing beacon

