

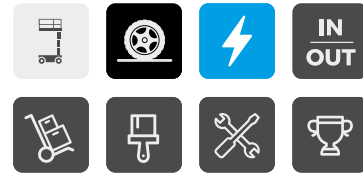

# STAR 13



## GO EVERYWHERE

- > Smooth & precise driving
- > Comfort & agility
- > Indoor / outdoor rated (versatile)
- > Easy entry to the platform
- > Smart transportability and lifting

## THE BEST VALUE FOR THE MONEY

- > Haulotte Activ'Energy Management takes care of your batteries
- > Easy access to components
- > Smart mast system
- > Minimal maintenance & downtime
- > Direct electric drive brushless AC motor
- > Haulotte Activ'Screen (onboard diagnostics)



866 874-0584 AERIALTITANS.COM

## VERTICAL MASTS

## TECHNICAL DATA

### STAR 13

|                                       |                               |
|---------------------------------------|-------------------------------|
| Working height                        | 18 ft 6 in                    |
| Platform height                       | 12 ft 6 in                    |
| Horizontal outreach                   | N/A                           |
| Lift capacity                         | 507 lb (2 pers.)              |
| Lift capacity - outside               | 507 lb (1 pers.)              |
| <b>A</b> Length                       | 4 ft 7 in                     |
| <b>B</b> Width                        | 2 ft 7 in                     |
| <b>C</b> Height - stowed              | 5 ft 11 in                    |
| <b>D</b> Wheelbase                    | 3 ft 6 in                     |
| <b>E</b> Ground clearance             | 2.36 in                       |
| Platform size                         | 2 ft 6 in x 4 ft 6 in         |
| Platform size with extension (option) | 2 ft 6 in x 4 ft 6 in + 16 in |
| Drive speed                           | 0.5 - 2.8 mph                 |
| Turning radius - outside              | 5 ft 7 in                     |
| Tilt alarm                            | 1.5 ° / 3 °                   |
| Gradeability                          | 25 %                          |
| Driveable at full height up to        | 12 ft 6 in                    |
| Tires                                 | 13 x 5                        |
| Batteries                             | 12 V - 105 Ah (C5)            |
| Weight                                | 2,006 lb                      |

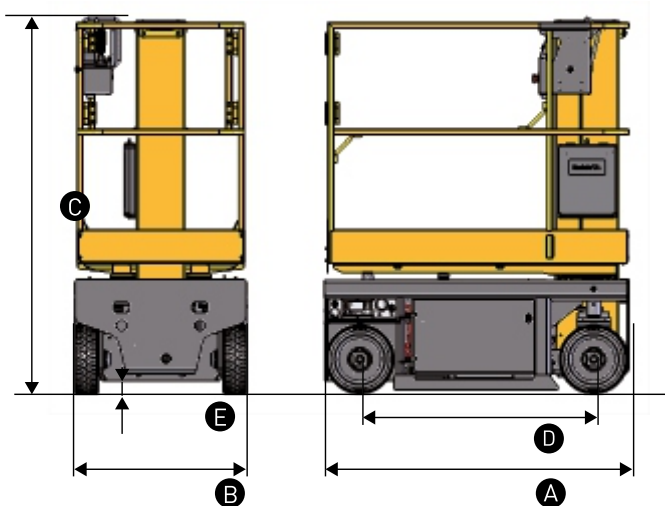

## STANDARD EQUIPMENT

- > Haulotte Activ'Energy Management: Smart CAN charger
- > 24 V electric drive brushless AC motors
- > 2 x 12 V - 105 Ah batteries
- > Battery charge indicator
- > Haulotte Activ'Screen
- > Forklift pockets
- > Hoisting and lifting eyes
- > Saloon door entry gate
- > Mobile pothole protection
- > 2 Front steering wheels
- > 2 Rear drive wheels
- > Non-marking tires
- > Brake release
- > Hourmeter
- > Horn
- > Travel alarm
- > Emergency stop
- > Emergency hand pump
- > 2 control stations at platform and ground level
- > Mobile upper control box
- > 2 towing hooks
- > Walkable entry plinth
- > Overload sensor

## OPTIONS AND ACCESSORIES

- > Haulotte Activ'Energy Management: automatic or manual battery waterfilling systems
- > Upper control box cover
- > Tool tray
- > 16 in platform extension deck (stowed height 5 ft 9.5 in) standard in US & Canada
- > Power to the platform
- > Ground-fault circuit interrupter 30 mA
- > Telematics ready
- > Biodegradable hydraulic oil
- > Cold weather hydraulic oil
- > Flashing beacon
- > Fluorescent tube caddy

