



**3522 A / 3632 T**  
**4527 A / 5533 A**  
**6543 A**



### EASE OF INSTALLATION

- > Can be towed by a standard half-ton pickup truck - No commercial driver's license needed
- > Hydraulic outriggers and automatic leveling allow operation in under 30 seconds

### EXCEPTIONAL PRODUCTIVITY

- > Safe elevation on slopes up to 12.5 degrees
- > 100% Battery powered with optional generator for extended duty cycles
- > Superior combination of industry leading capacity and outreach
- > Air / water lines and 110V GFI protected power to the platform

### LOW MAINTENANCE

- > Electronic controls simplify operation and minimize hydraulic hoses



866 874-0584 AERIALTITANS.COM

# 3522 A / 3632 T / 4527 A 5533 A / 6543 A

## AERIAL TITANS TRAILER-MOUNTED BOOMS

### TECHNICAL DATA

	3522 A	3632 T	4527 A	5533 A	6543 A
Working height	41 ft 9 in	43 ft 6 in	51 ft	61 ft 3 in	71 ft
Platform height	35 ft 9 in	37 ft 6 in	45 ft	55 ft 3 in	65 ft
Horizontal outreach (from centerline)	22 ft 6 in	32 ft	27 ft	33 ft 5 in	43 ft
Horizontal outreach (from edge of footpad)	17 ft 5 in	27 ft	21 ft	27 ft 4 in	37 ft
Up and over height	19 ft	N/A	20 ft 9 in	23 ft 1 in	24 ft 2 in
Lift capacity	500 lb				
<b>A</b> Length - stowed	16 ft 3 in	22 ft 8 in	20 ft 8 in	23 ft 8 in	24 ft
<b>B</b> Width stowed	5 ft 6 in		5 ft 7 in		5 ft 11 in
<b>C</b> Height stowed	6 ft 8 in		6 ft 9 in		7 ft
<b>D</b> x <b>E</b> Platform size	4 ft 1 in x 2 ft 9 in				
<b>F</b> Widest Point	11 ft 10 in	13 ft 9 in	14 ft 8 in		
<b>G</b> Widest Point	12 ft 2 in	13 ft 6 in	15 ft		
Turntable rotation	350° non-continuous				
Jib - length	4 ft 3 in				
Jib - Vertical Motion	150° (+70 / - 80)				
Tow speed rating	65 mph				
Leveling capability	12.5 °				
Tire size	ST 225 / 75 D15	ST 225/75 R15		215/75R 17.5	
Power source	4 x 6 V 245 amp-hr				
Tongue weight (no options)	245 lb	200 lb	290 lb	335 lb	550 lb
Weight (no options)	3,400 lb	4,400 lb	4,200 lb	4,800 lb	7,700 lb

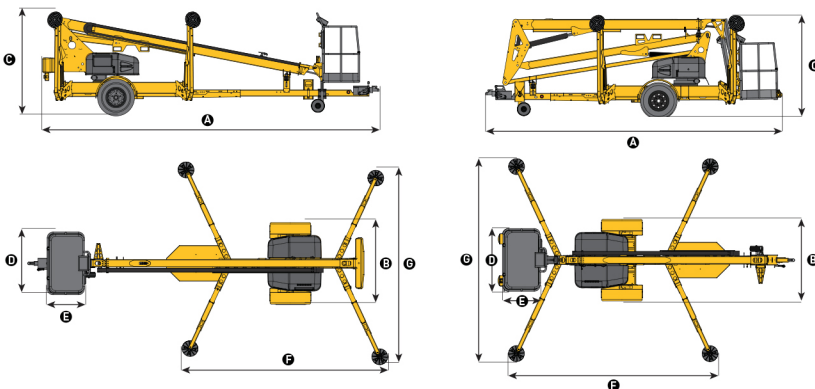

### STANDARD EQUIPMENT

- > Hydraulic outriggers
- > Automatic leveling system and self-leveling platform
- > 110V GFI protected outlet to platform
- > Tilt alarm/sensor
- > Hour meter and battery condition indicator
- > Easy to use controls
- > Air and water line to platform
- > Inboard 25 amp charger
- > Integrated forklift pockets
- > Hydraulic surge brakes (trailer)

### OPTIONS & ACCESSORIES

- > Spare tire and mounting kit
- > DC / Gas hybrid
- > Manual platform rotator - 120° stop point to stop point
- > Flashing beacon
- > Fluorescent tube caddy
- > Tool tray
- > Electric brakes (trailer)
- > Drive and Set (Not available on 3522 A & 6543 A)

#### 3632 T

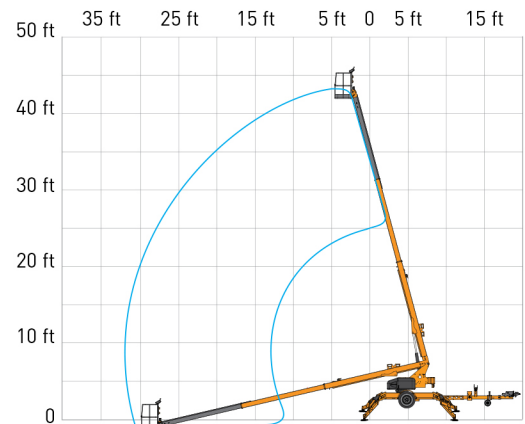

#### 3522 A 4527 A 5533 A 6543 A

